

OvisLink Technologies

OV220

Media Converter Module

User's Manual

(Ver 1.0)

Table of Contents

1.	Introduction.....	3
2.	Description of front board.....	3
3.	Light indication description.....	4
4.	Installation and mage.....	5
	4.1.1 Installation.....	5
	4.1.2 Getting started.....	5-6
5.	Specification.....	7
	5.1.1 Optical specification.....	7
	5.1.2 Other specification.....	7
6.	The rule of probation's name.....	8
7.	Trouble shooting.....	8-9

1. Introduction

OV220 Series Media Converter is primarily designed for large, high speed/bandwidth demanding workgroups that require expansion of the fast Ethernet network. They can be used to extend the transmission distance between two Fast Ethernet Twisted-pair devices via fiber cable transparently with no performance degradation.

OV220 Series Media Converter includes 100Mbps and 10/100Mbps. There are stand-alone media converters and media converter modules. OV220M Media Converter can transmit 2KM(MM), 20KM, 40KM, 60KM and 120KM.

2. OV220M Media Converter front board description

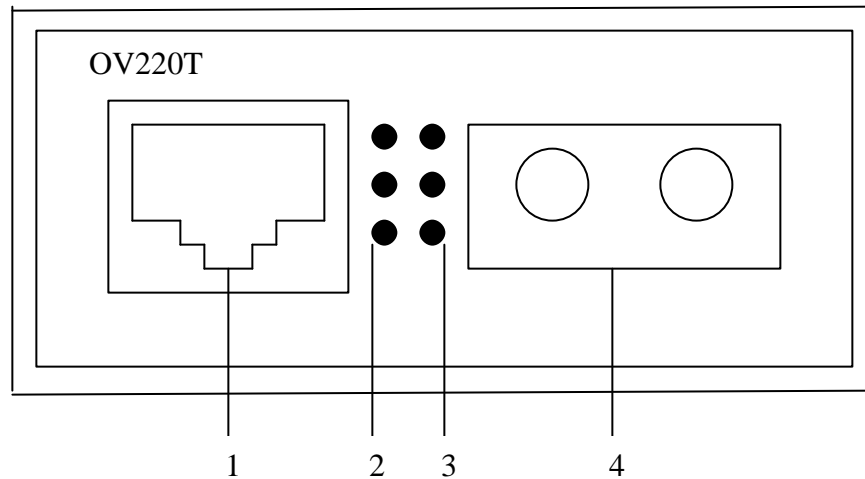

1. RJ45

2. Left Light Indication (Twist pair)

3. Right Light Indication (Optical)

4. Optical SC/PC interface

3. OV220 Series Media Converter Light Indication Description

There are 6 LED Lights on the front board. They indicate all kinds of work status. Details as follows.

Left 3 Lights indication below:

ACT – Twisted pair interfaces connect/receive Light, “Lights up” when twisted pair link is connected; “Flashes” when Media Converter is receiving data; “Lights off” when the twisted pair is disconnected.

CVT – Data transmitting Light. When “Flashing”, data has been transmitted and exchanged.

FDX – Full/Half Duplex Light. “Lights up” when full duplex; “Lights off” when half duplex.

Right 3 lights indications below:

ACT – Optical Fiber connect/receive light. “Lights up” when optical link is connected; “Flashing” when optical link is well connected and is receiving data; “Lights off” when optical link is disconnected.

CVT – Data transmitting light. “Flashes” when data has been exchanged.

PWR – Power indication light.

4. Installation and Usage

Make sure whether optical fiber(SM or MM) and power supply match Media Converter before installation.

4.1.1 Installation

Plug the power supply in the power supply slot; management card in the management slot and media converter cards in left 15 slots. Also put the 19-inch rack onto the shelf.

4.1.2 Getting Started

(1) Correct Connection between mode and setting of working mode.

Mode setting before power off.

Modes setting take offset with front panel switch.

OV220 Series Media Converter all support auto-negotiation. If equipment connected has auto-negotiation, auto-negotiation mode. If different working mode required, please make sure same working mode between Media Converter and Ethernet equipment. If equipment connected to Media Converter be set on 100Mbps/half duplex, because of limitation of CSMA/CD protocol, distance between switching and optical fiber does not exceed 400m.

Every type of Media converter has work mode setting switch aiming at twist-pair port. Setting switch is two-bit bytes switch, switch 1 set duplex mode: Full Duplex Half Duplex.

Switch 2 Auto-Negotiation: Auto – Negotiation on, Auto – Negotiation off

1. Cut off power before changing switch status.

2. Media Converter port's read work mode with auto-negotiation on is related to the other side equipment.

3. Don't make Media converter work in prohibitive state.

(2) Prepare the twisted-pair connecting to switching when the Media converter connect to DCE equipment an Ethernet switch use cross-twist pair, twist pair parried to RJ-45 port: when connected to DTE equipment.

(3) Power on.

(4) Connect Twist Pair to RJ-45 port, optical fiber to SC/PC port. Please make sure that twisted-pair is nice and tight and fiber connector should satisfy related criterion. OV220 series Media Converter under MDI mode ping definition of RJ-45.

(5) Installation finish

Pin	1	2	3	4	5	6	7	8
Function	TX+	TX-	RX+	Not Used	Not Used	RX-	Not Used	Not Used

5. Specification

5.1.1 Optical Specification

Product Type	Bandwidth Wavelength	Fiber Type	Trans moist pacer	Receiving sensitivity	Light saturation	Estimate transmit distance
OV220 [] – 02 []	850	MM	-20 ~ -14	-31dBm	-12 dBm	0~2
OV220 [] – 20 []	1310	SM	-20 ~ -12	-31dBm	-3 dBm	0~20
OV220 [] – 40 []	1310	SM	-12 ~ -5	-35dBm	-3 dBm	0~40
OV220 [] – 60 []	1310	SM	-5 ~ 0	-35dBm	-3 dBm	10~60
OV220 [] –120 []	1550	SM	-5 ~ 0	-35dBm	-3 dBm	15~120

5.1.2 Optical Specification

Criterion	OV220N series: IEEE802.3u, IEEE802.1q and ISL(Cisco) OV220A series: IEEE802.3, IEEE802.3u and IEEE802.1q
Optical Interface	SC/PC, ST/PC, SC/APC
Twisted-Pair Interface	RJ-45
Transmit Mode	OV220N series: Half/Full Duplex, 100Mbps OV220A series: Half/Full Duplex, 10/100Mbps
Transmit Pattern	OV220N series: bit for ward OV220A series: store-and-forward
Max filtrate speed	148800pps (Auto-sense series)
Max forwardly speed	148800pps
Power input	90~260VAC, 50~60Hz
	6W
Work Temperate Scope	- 10 ~ 50 ?C
Store temperate scope	-25 ~ 65 ?C
Ratlines size	132 x 122 x 39 mm

6. The rule of probation's name

Naming regulation of OV220 series Media Converter ad follows:

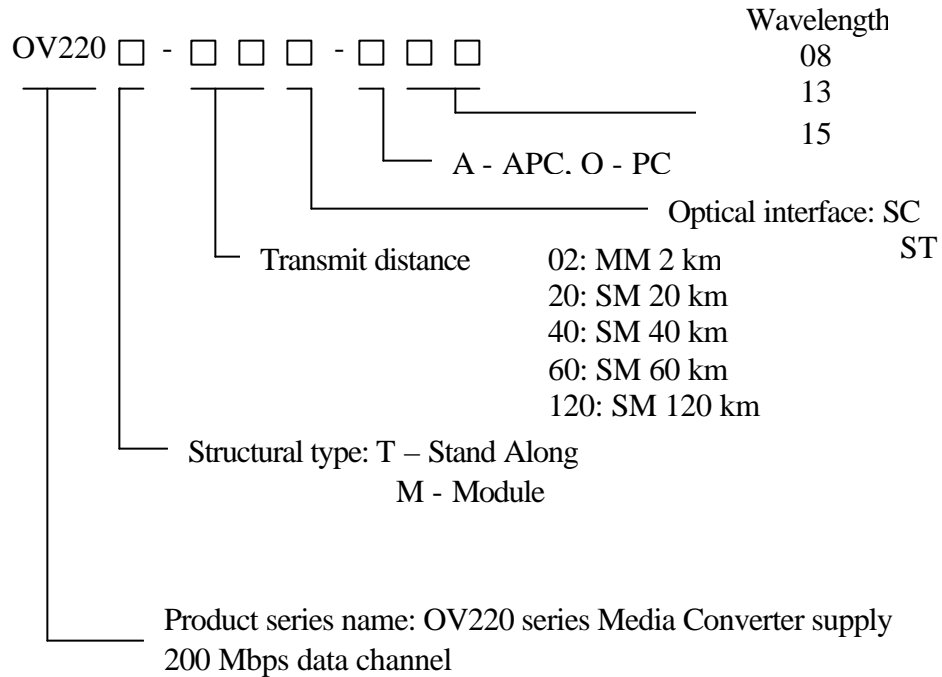

7. Trouble shooting

Checking Media Converter working statue after power on, referring to Media Converter indication light. If work abnormally, refer to following steps with troubles checking.

(1) Power indication light off

Check if connection of power play is correct, power supply match the requirement of Media Converter.

(2) CVT indication light off besides twisted pair

Check if the cross/connect of twist pair is correct, check if the of twist pair correct; check your Ethernet equipment work normally. To auto-sense

100 Mbps series products make sure your Ethernet equipment has already been set to 100Mbps.

(3) Optical port CVT indication light off

Check if optical connector and optical port type match, if panel is clear, if well plug into optical connector, if XMT connect another RCV, check if your Ethernet equipment works correctly. If fiber is open circuit, check if your Ethernet equipment works normally.

(4) All lights on, but link does not work

Check if Ethernet equipment connected and if the Media Converter works normally.

Any problems similar to the above situations then use the solutions above. If problem persists, please contact your suppliers.